

DETAIL A

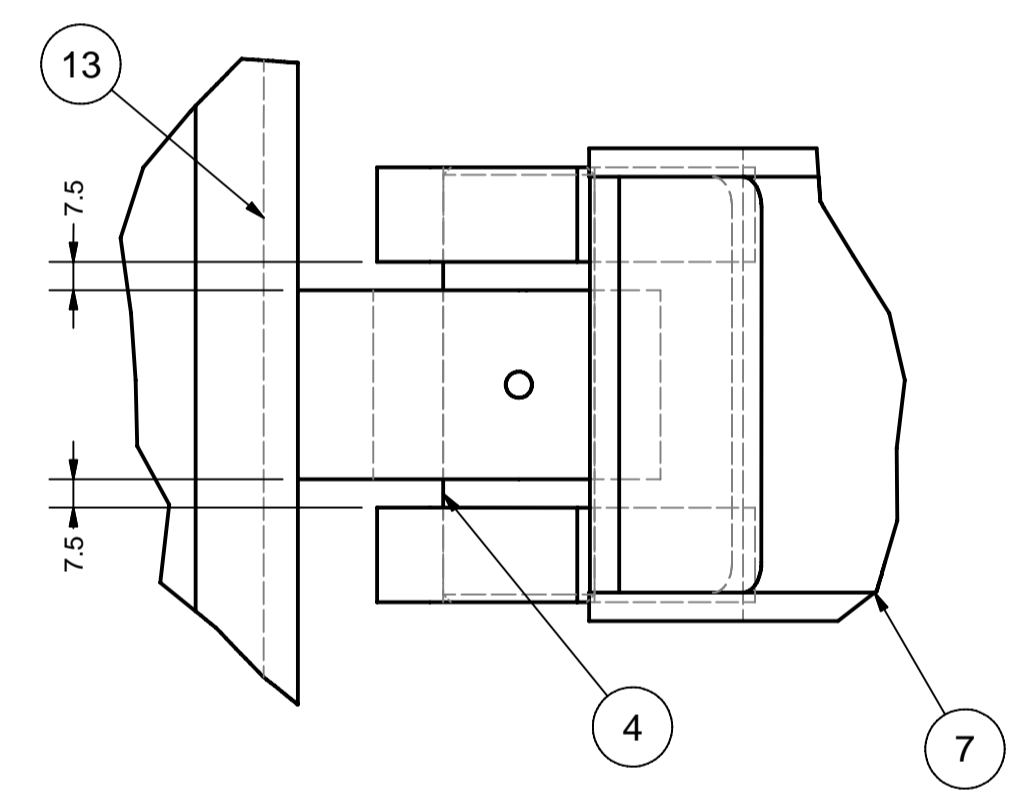

DETAIL B

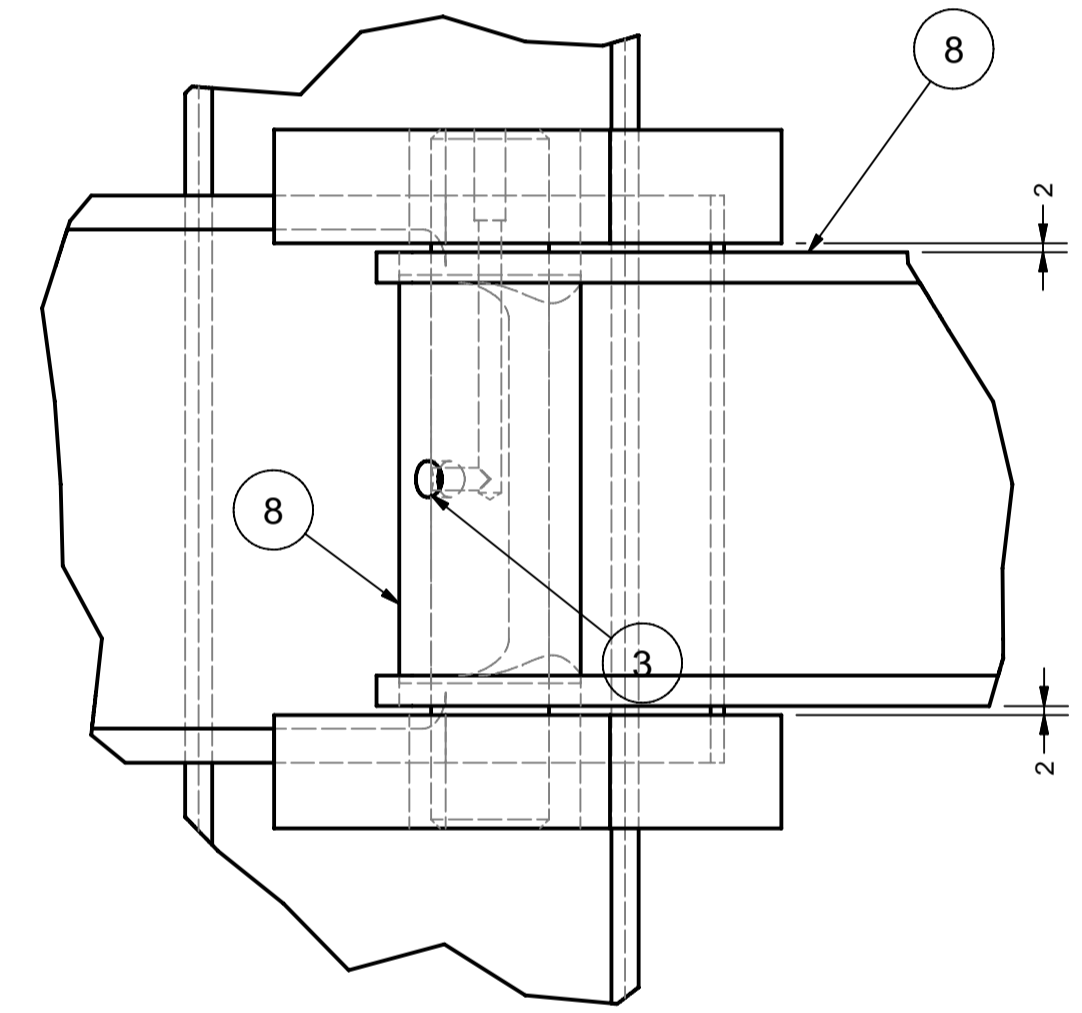

DETAIL C

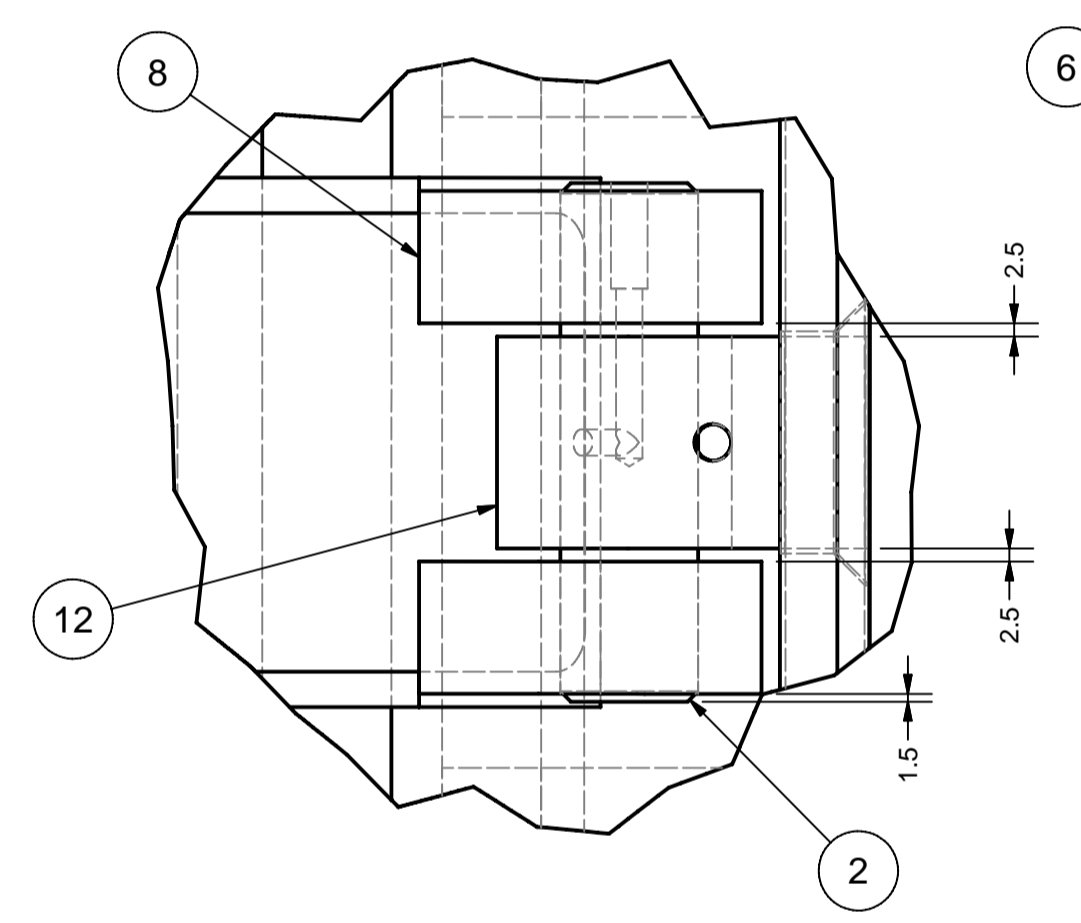

DETAIL D

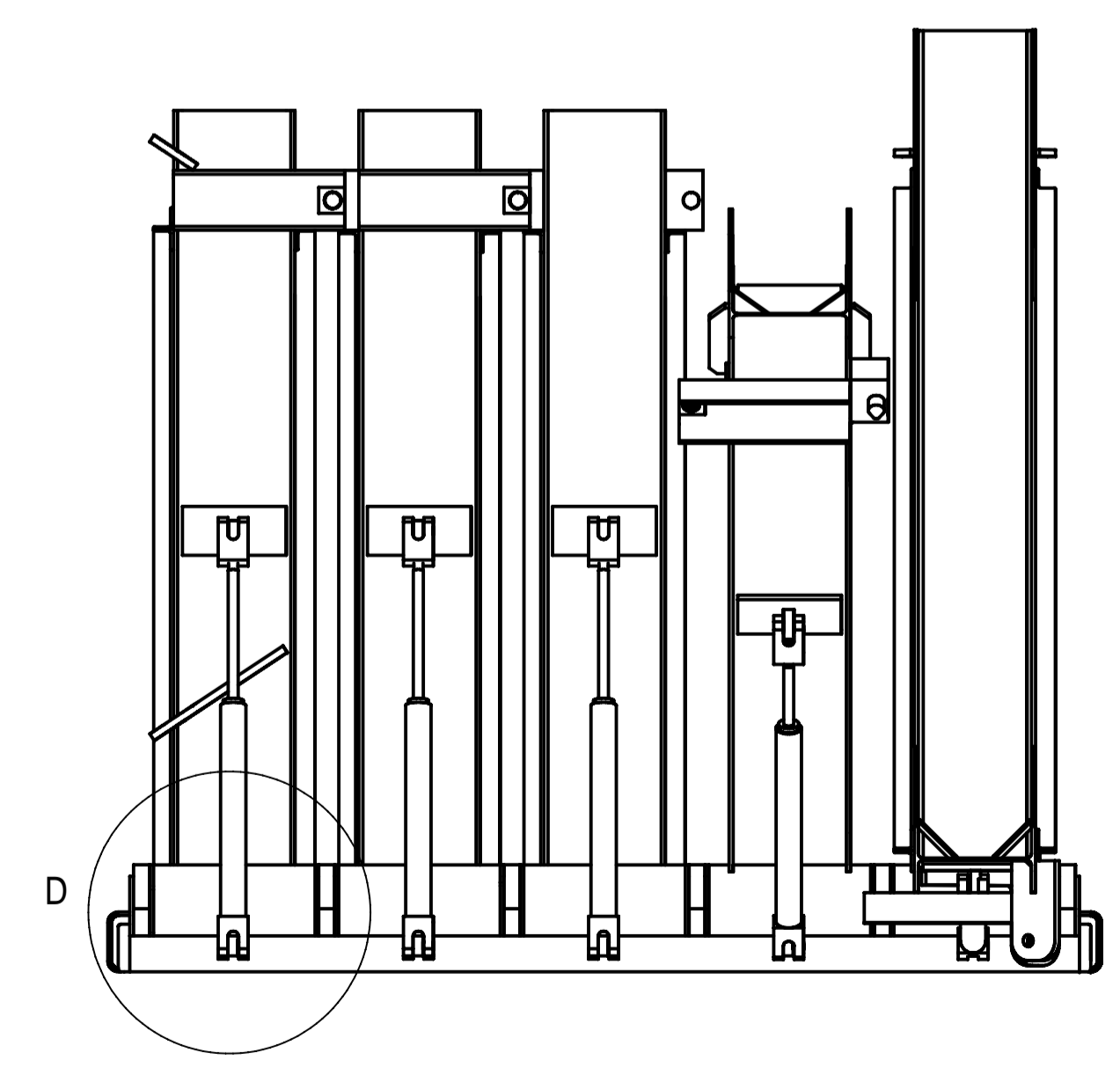
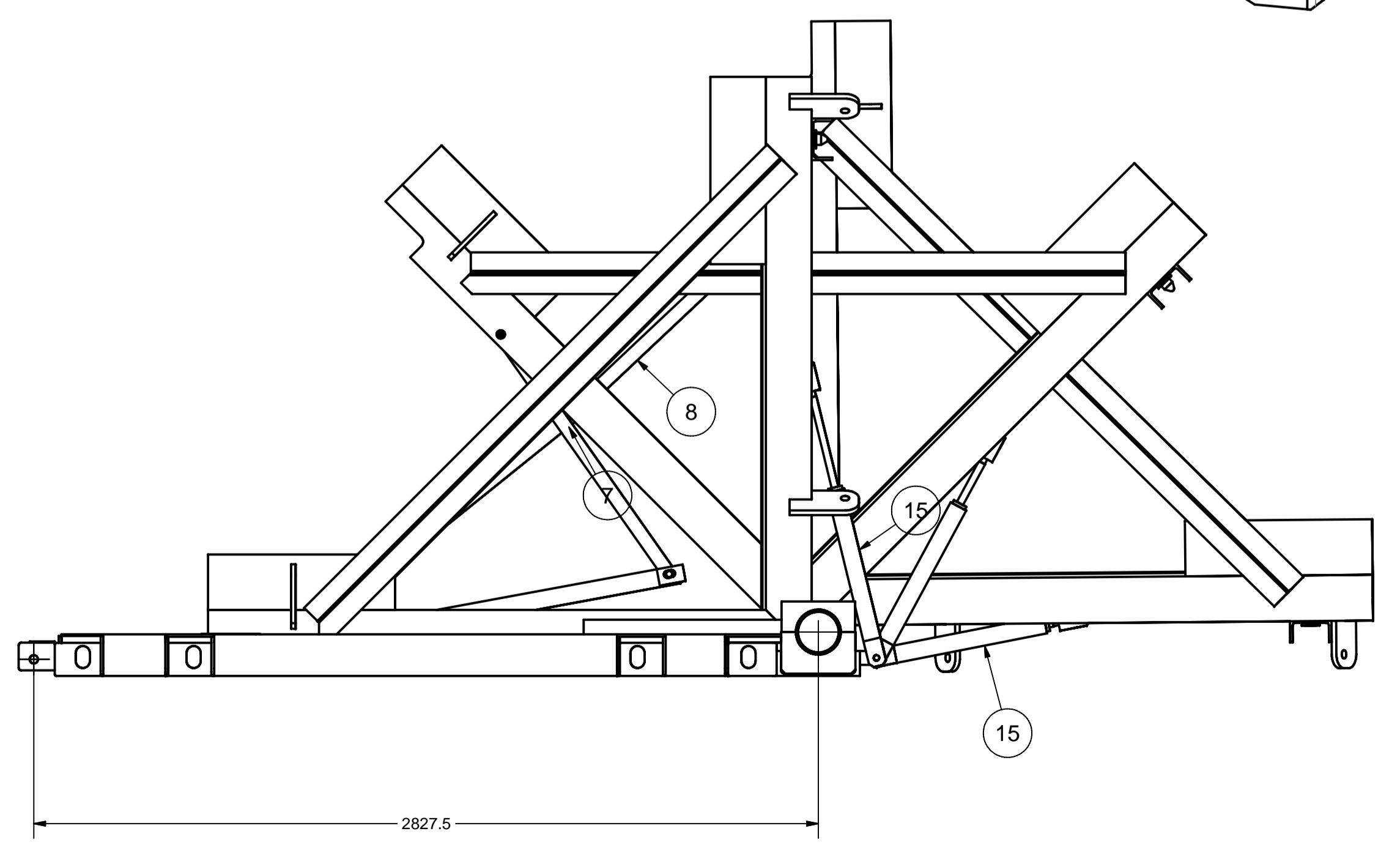
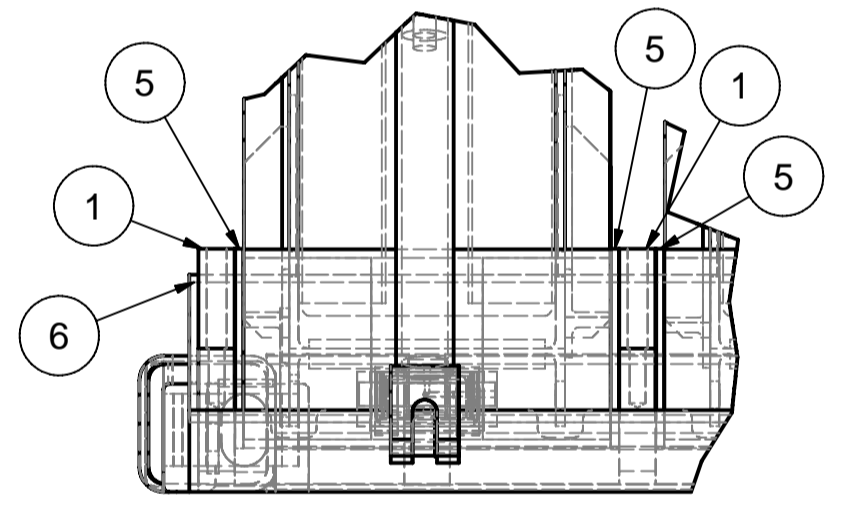

ITEM	PART NUMBER	QTY
15	CYLINDER ASSEMBLY 2	5
14	001TT-2011	1
13	001TT-2010	1
12	001TT-2005	1
11	001TT-2004	1
10	001TT-2003	1
9	001TT-2002	1
8	001TT-1002	5
7	001TT-1001	5
6	001TT-0093	1
5	001TT-0083	10
4	001TT-0018	5
3	001TT-0017	5
2	001TT-0016	5
1	001TT-0012	6

DATE	REVISION	BY	CHK'D	PROJ. NO.	CLIENT	TITLE
30/9/05	ISSUED FOR FABRICATION	G.M. K.R.		BEST-5001	BURKE ENGINEERING SERVICES	TILT PANEL TRANSPORTATION CRADLE
14/10/05	DETAIL SIZE AND BALLONS ALTERED	G.M. K.R.		DRN. BY: Kevin Rudd	P.O. BOX 330	SUBJECT: TILTING FRAME ASSEMBLY
				DATE: 31/08/2005	EAST MAITLAND N.S.W. 2323	DESCRIPTION: ASSEMBLY DETAIL
				CHECKED BY: K. RUDD	Ph: (02) 4933 9990	SHEET No: 1 of 1 DRAWING NO: 5001TT.iam
				APPROVED BY: J. BURKE	Fax: (02) 4933 9991	

COPYRIGHT EDORAS PTY LIMITED TIA 3D ENGINEERING SOLUTIONS
 ANY FORM OF REPRODUCTION OF THIS DRAWING IN FULL OR IN PART WITHOUT THE WRITTEN PERMISSION OF EDORAS PTY LIMITED CONSTITUTES AN INFRINGEMENT OF COPYRIGHT.

ENGINEERING SOLUTIONS
 Ph: 61 2 4933 6011 Fax: 61 2 4933 6022